

BLU 15000.1 PR
BLU 18000.1 PR



Technical data



Operating instructions



Electric diagrams



Spare parts list



Gas train manual is separate



420010451100

BLU 15000.1 PR TC SGT 230-400-50	3142592
BLU 18000.1 PR TC SGT 230-400-50	3142593

INDEX

BLU 15000.1 PR

BLU 18000.1 PR

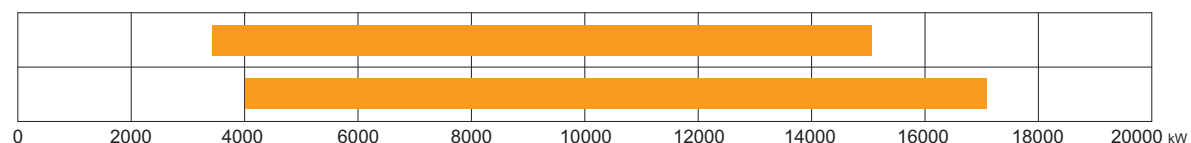

General warnings - Conformity declaration	3
Burner designation - Modular delivery system	4
Burner description	5
Electrical control panel	5
Gas train - Kit - Accessories: assembly to the burner	6
Technical data	7
Gas category by country	7
Working fields	8
Test boiler - Flame dimension	8
Overall dimensions	9
Gas operating mode - General safety functions	10
Installation	11
Fitting the burner to the boiler	11
Gas line	12
Pilot gas train, kit and accessories connection - Head loss diagram	13
Pressure loss diagrams	14
Electrical connections	16
Start-up: checking procedure	17
Exhaust gas test	18
Start-up	19
Adjusting the max air flow rate	19
Firing head setting	19
Servomotor pre-setting	19
Adjusting the intermediate burner capacity	20
Pressure switch adjustment	20
Servomotor: final setting	20
Maintenance program	21,22
Troubleshooting instructions	23
Operating troubles	24
Appendix	25
Control box - Damper actuators	25
Electrical diagrams	26
Spare parts list	28

GENERAL WARNINGS - CONFORMITY DECLARATION

BLU burners are designed for the combustion of natural gas or LPG with kit. The design and function of the burners meet the standard EN676. They are suitable for use with all heat generators complying with standard within their respective performance range. Any other type of application requires the approval of ECOFLAM.

Installation, start-up and maintenance must only be carried out by authorised specialists and all applicable guidelines and regulations must be complied with.

BURNER DESCRIPTION

BLU burners are progressive mechanical fully automatic monoblock devices. Emissions values may differ, depending on combustion chamber dimensions, combustion chamber load and the firing system (three-pass boilers, boilers with reverse firing).

PACKAGING

The burner, the gas train and all the additional components are supplied in a modular system of packages according to the configuration ordered that based on the country of installation shall follow the applicable standards and the local rules and code of practise. The following standards should be observed in order to ensure safe, environmentally sound and energy-efficient operation:

EN 676
Forced-draught gas burners

EN 60335-1, -2-102
Specification for safety of household and similar electrical appliances, particular requirements for gas burning appliances

GAS LINES

When installing the gas lines and gas train, the general EN676 directives and guidelines must be observed.

EN676 compulsory kit and accessories in order to comply to the safety regulations. Additional accessories and kits shall be installed by the installer in accordance to the local safety regulations and codes of practise.

INSTALLATION LOCATION

The burner must not be operated in rooms containing aggressive vapours (e.g. spray, perchloroethylene, hydrocarbon tetrachloride, solvent, etc.) or tending to heavy dust formation or high air humidity. Adequate ventilation must be provided at the place of installation of the furnace system to ensure a reliable supply with combustion air.

Declaration of conformity for gas burners

We,
Ecoflam Bruciatori S.p.A.

declare under our sole responsibility that the products:

BLU 15000.1 PR
BLU 18000.1 PR

conform to the following standards:

EN 676: 2008
EN 60335-1: 2008
EN 60335-2-30: 2006
EN 60335-2-102: 2007
EN 55014-1: 2008 + A1: 2009
EN 55014-2: 1998 + A1: 2001 + A2: 2008

These products are built in accordance with the following directives
2006/42/EC Machinery directive
2004/108/EC EMC directive
2006/95/EC Low voltage directive
2009/142/EC Gas appliances Directive

CE certification, when required, must be done at installation site by the end user

Resana, 20th December 2010
M. PANIZZON



BURNER SELECTION: Type of operation and configuration must be done by professional personnel in order to grant correct working of the burner. Installation, start-up and maintenance must be carried out by authorised specialists and all applicable guidelines and regulations (including local safety regulations and codes of practise) must be observed.

We accept no responsibility for damage arising from:

- inappropriate use;
- incorrect installation and/or repair on the part of the buyer or any third party, including the fitting of non-original parts;
- non authorised modifications made on the burner.

Final delivery and instructions for use

The firing system installer must supply the operator of the system with operating and maintenance instructions on or before final delivery. These instructions should be displayed in a prominent location at the point of installation of the heat generator. They should include the address and telephone number of the nearest customer service centre.

Notes for the operator

The system should be inspected by a specialist at least once a year. Depending on the type of installation, shorter maintenance intervals may be necessary. It is advisable to take out a maintenance contract to guarantee regular servicing.

Ecoflam burners have been designed and built in compliance with all current regulations and directives.

All burners comply to the safety and energy saving operation regulations within the standard of their respective performance range. The quality is guaranteed by a quality and management system certified in accordance with ISO 9001:2008.



BURNER DESIGNATION

BLU 8000.1 PR TC SGT 230-400-50

RANGE NAME BY FUEL TYPE

BLU	Gas
-----	-----

MODEL SIZE (Gas: kW; Oil: kg/h)

BLU 8000.1	8000 kW
------------	---------

EMISSIONS

	Standard Class 2 - GAS EN676 (<120 mg/kWh)
LN	Low NOx Class 3 - GAS EN676 (<80 mg/kWh)

OPERATION TYPE

PAB	2 stages soft start
PR	2 stages progressive mechanical
E	2 stages modulating electronic

HEAD TYPE

TC	Short head
TL	Long head

FUEL

	Natural gas
LPG	Liquid gas
BIOGAS	Biogas

EQUIPMENT

SGT	Separate gas train
-----	--------------------

ELECTRICAL POWER SUPPLY

230-400-50	230-400 Volt, 50 Hz
------------	---------------------

MODULAR DELIVERY SYSTEM

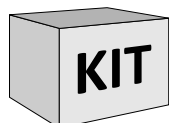
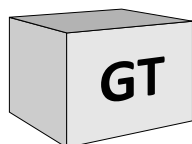
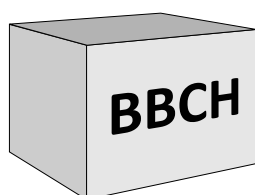

Gas burners

All gas burners are delivered in separate set/box, i.e. burner body including combustion head and separate gas train with separate additional kit and accessories that shall complete the gas train or the burner according to the applicable standard. Kit and accessories are delivered separately.

Gas train - GTCP - KITS - Accessories

All gas and dual fuel burners gas trains are delivered separately in different models and configuration.

Export configuration gas train completion are available but it is mandatory for the local installer in this case to comply to the local safety regulations.

For burners over 1700 kW gas train connection pipe must be ordered.

Kits and accessories are managed and delivered separately.

Component type

BBCH	Burner Body with Combustion Head (without gas train)
GTCP	Gas Train Connection pipe
GT	Gas Train (delivered separately)

BURNER DESCRIPTION

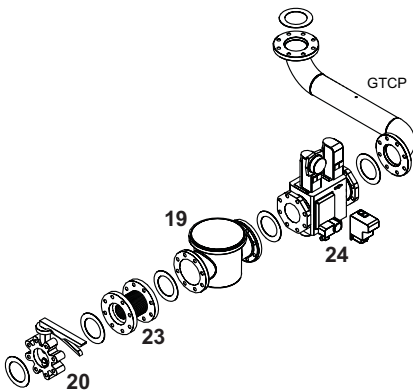
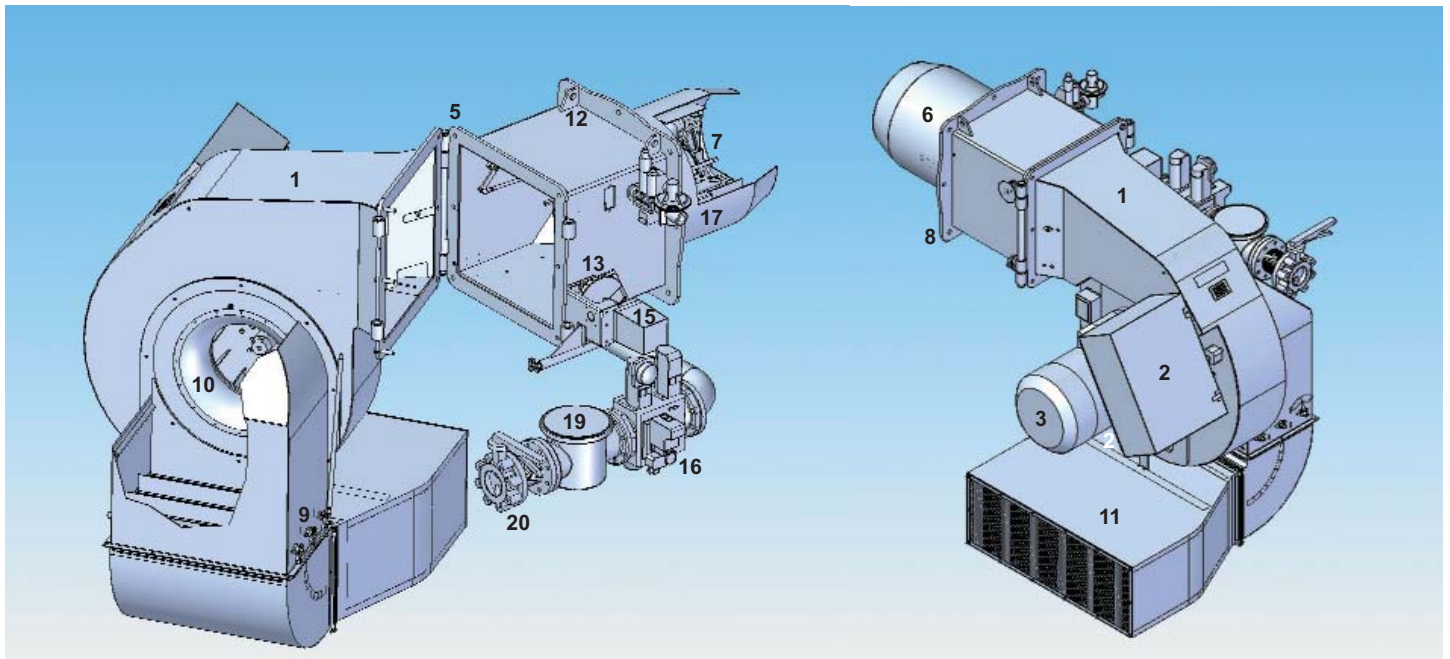

LEGENDA

- | | |
|-----------------------------|---------------------------------|
| 1. Housing | 12. Lifting eyebolts |
| 2. Electrical control panel | 13. Mechanical cam gas |
| 3. Blower motor | 15. Servomotor for gas and air |
| 5. Hinge flange | 16. Gas train |
| 6. Blast tube | 17. Pilot gas train |
| 7. Burner head | 19. Gas filter |
| 8. Burner fixing flange | 20. Ball valve |
| 9. Air flap regulation | 23. Antivibration coupling |
| 10. Fan wheel / blower | 24. Tightness control |
| 11. Silencer | GTCP. Gas train connection pipe |

Control panel

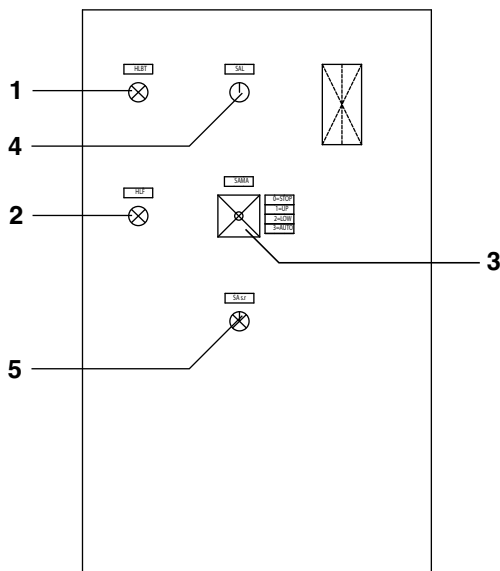

- 1 - Thermal lock-out lamp
- 2 - Working lamp
- 3 - Selector :
 - 0 Locking of devices for operating at intermediate outputs
 - 1 Operation at max. output
 - 2 Operation at min. output
 - 3 Automatic operation
- 4 - Main switch I / O
- 5 - Lockout disable push button

BURNER DESCRIPTION

Gas train - Kit - Accessories: assembly to the burner

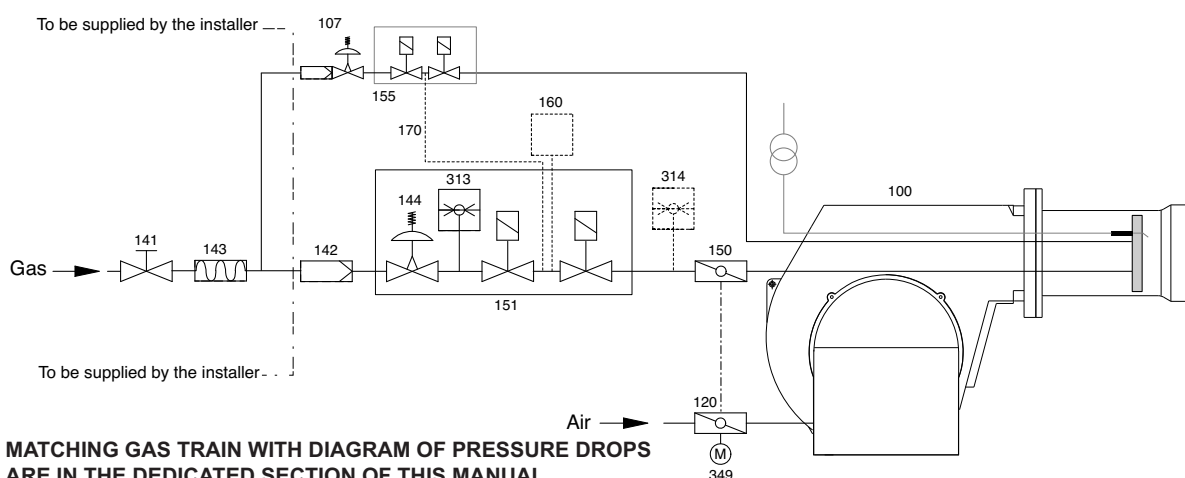

MATCHING GAS TRAIN WITH DIAGRAM OF PRESSURE DROPS ARE IN THE DEDICATED SECTION OF THIS MANUAL

Ecoflam gas trains are delivered separately for all gas and dual fuel burners and are available in different configurations:
Double gas valves with actuators and regulator VGD Siemens and min pressure switch + ACS gas filter

VGD 20.503 Rp 2" / VGD 40.065 - 40.080 - 40.100 - 40.125				
	1. Main gas pipe			
	2. Ball valve		ACS	
	3. Antivibration coupling		ACS	
	5. Min gas pressure switch	EXPORT	GAS TRAIN	EN676
	6. Safety gas valve + 10. Actuator			
	7. Working gas valve + 11. Actuator			
	8. Gas leakage control	KITTC *		
	9. Gas filter	ACS		
	KIT - MAX Gas pressure switch	KITPRES		
	ACS - Gas train connection pipe	GTCP **		

! **GTCP-...*** **WARNING:** in order to fit the gas train, the corresponding connection pipe must be ordered (GTCP size and fitting depend on the burner and the gas train selected).

HOW TO INSTALL THE GAS TRAIN INTO THE BURNER AND CALCULATE THE OVERALL DIMENSIONS:

refer to the dimension page and the gas train manual for all detailed information

! **WARNING:** EN676 compulsory kit and accessories in order to comply to the safety regulations. Additional accessories and kits shall be installed by the installer in accordance to the local safety regulations and codes of practise.

Gas governor / Filter	Tightness control	Modulation Kit	Max Pressure switch	Other accessories
FGDR - FILTER	KITTC- Model	KITMD-RWF40	KITPRES50	
Compulsory EN676	Compulsory > 1200 kW	Probe...	KITPRES150	

TECHNICAL DATA

MODEL		BLU 15000.1	BLU 18000.1
Thermal power max.	kW	15.000	17.000
	kcal/h	12.900.000	14.620.000
Thermal power min.	kW	3.690	4.000
	kcal/h	3.173.400	3.440.000
Operation mode	Type	Progressive mechanical gas - Modulating with PID	
Regulation ratio nominal	Type	1+4 GAS	
Fuel	Type	G20 (L.C.V. 8.570 kcal/Nm ³), G25 (L.C.V. 7.370 kcal/Nm ³) G31 (L.C.V. 22.260 kcal/Nm ³), G30 (L.C.V. 29.320 kcal/Nm ³)	
Emission class	std	Standard Class 2 - GAS EN676 (<120 mg/kWh)	
Control unit	Type	LFL / LGK	
Gas train	GT	VGD separate gas train + Filter + KIT Tightness control + Other KIT/ACS	
Gas connection	GTCP	Gas connection range DN80 to DN125 depending on the gas train selected	
NATURAL GAS pressure	mbar	150÷700	210÷700
LPG pressure	mbar	135÷700	190÷700
Air regulation	Type	Air flap	Air flap
Air flap control with servomotor	Model	SQM50	
Air pressure switch	mbar	1...10 mbar	
Flame monitoring	Type	Ionization	
Ignitier	Model	COFI	
Motor	kW	45	55
Rpm	N°	2.800	2.800
Voltage	V/Hz	230/400 V - 50 Hz	
Total power consumption operation	W	47.000	58.000
Weight body BBCH	Kg		
Electrical panel protection level	IP	IP55	IP55
Sound pressure level without silencer	dB(A) Lab tests	97,3	97,3
Sound pressure level with silencer		89,8	89,8
Ambient temperature storage	Min/Max	-20°...+70° C	
Ambient temperature use		-10°...+60° C	

GAS CATEGORY BY COUNTRY

Gas category	Country																								
	AT	BE	BG	CH	CY	CZ	DE	DK	EE	ES	FI	FR	GB	GR	HU	IE	IS	IT	LT	LU	LV	MT	NL	NO	PL
2,3 Family	PT	RO	SE	SI	SK	AL	HR	MK	TR	-	-	-	-	-	-	-	-	-	-	-	-	-	-	-	-

WORKING FIELDS

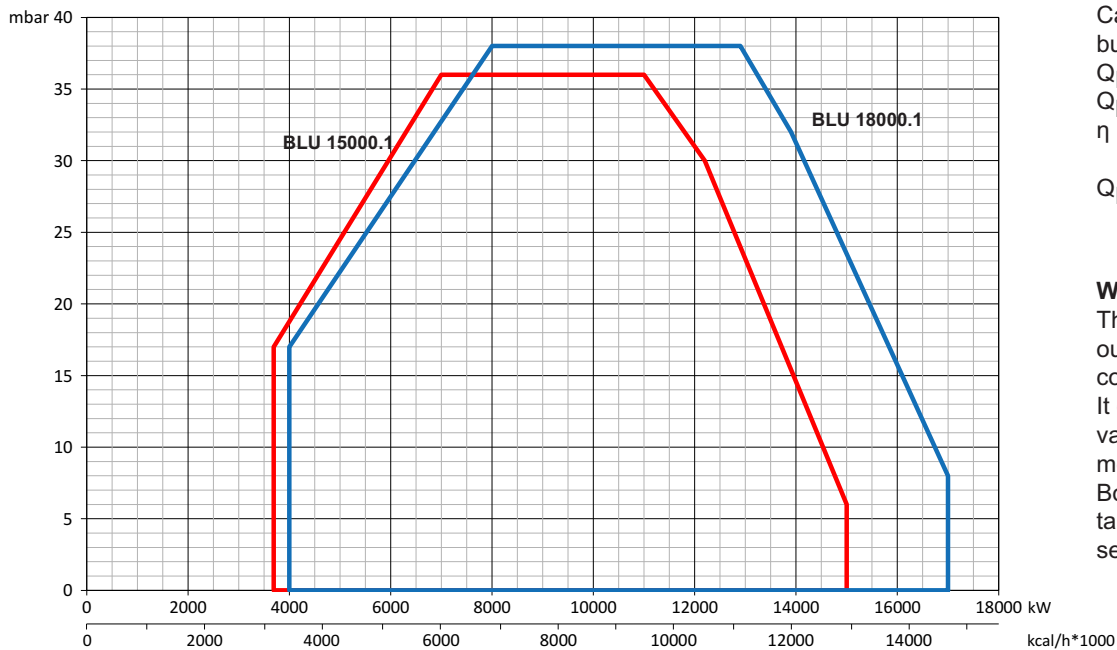

Calculation of burner output
 Q_F = Burner output (kW)
 Q_N = Rated boiler output (kW)
 η = Boiler efficiency (%)

$$Q_F = \frac{Q_N}{\eta} \times 100$$

Working fields

The working field shows burner output as a function of combustion chamber pressure. It corresponds to the maximum values specified by EN 676 measured at the test fire tube. Boiler efficiency should be taken into consideration when selecting the burner.

TEST BOILER - FLAME DIMENSIONS

FLAME LENGTH GAS BURNERS

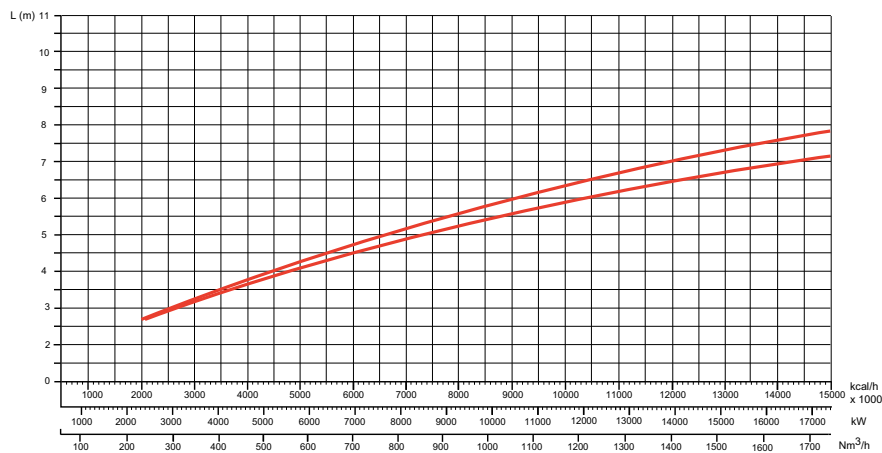

The burner/boiler matching does not pose any problems if the boiler is CE type-approved.

If the burner must be combined with a boiler that has not been CE type-approved and/or its combustion chamber dimensions are clearly smaller than those indicated in diagram, consult the manufacturer.

The firing rates were set in relation to special test boilers, according to EN676 - EN267 regulations.

The sizes are indicative and depend on the configuration, to the combustion chamber pressure and to the draught. The values have been taken out from tests executed with flame tubes.

FLAME DIAMETER GAS BURNERS

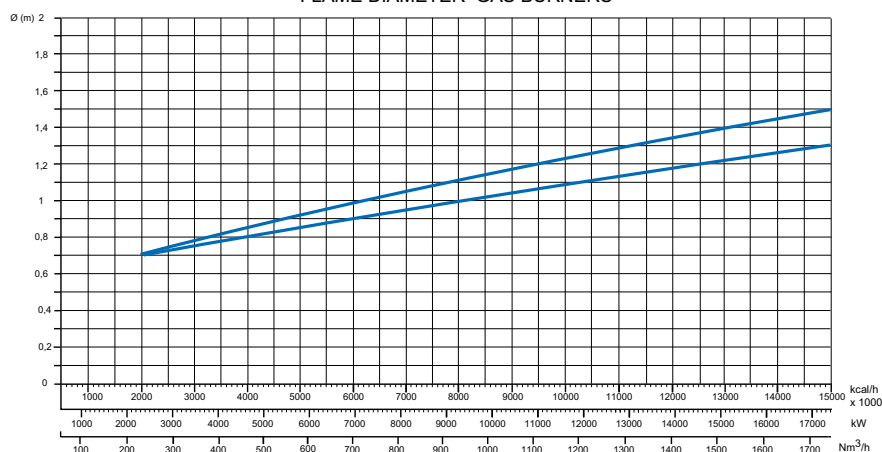

The dimensions of the flame are made in test boiler in laboratory without resistance therefore exists max and min length that take into account the difference in length that comes from the boiler backpressure.

Example:

Burner thermal output = 8000 kW;

L flame (m) = 5 m (medium value)

D flame (m) = 1 m (medium value)

WARNING: Some flame modifications can be done in our FLEXSHOP in the factory in order to shape the flame and adapt it to some special boiler or application.

OVERALL DIMENSIONS

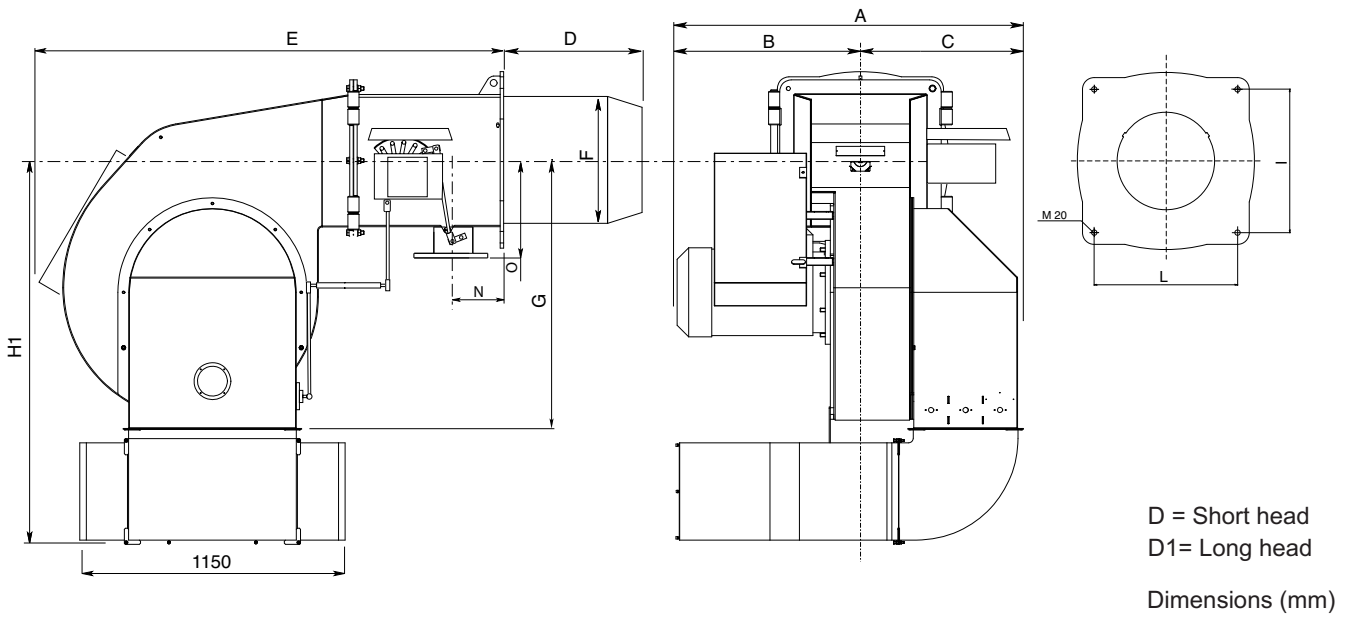

HOW TO INSTALL THE GAS TRAIN INTO THE BURNER AND CALCULATE THE OVERALL DIMENSIONS:

refer to the dimension page and the gas train manual for all detailed information

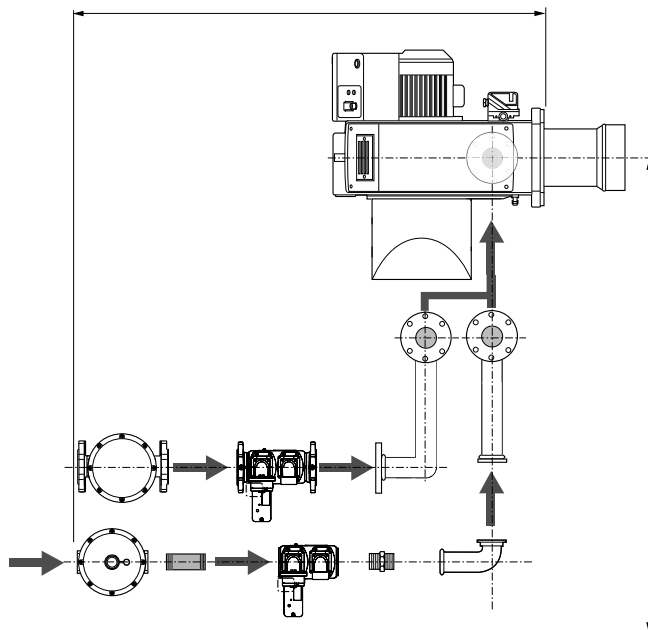

Burner-boiler mounting flange

Fixing hole dimensions are "I" and "L" as per dimension table. Boiler hole shall be done according to the blast tube dimension "F" plus 15-25 mm in order to be able to extract it during maintenance.

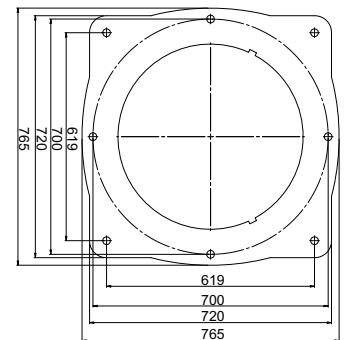

WARNING: Please follow the suggested dimension for the hole on the boiler flange in order to fit the burner. Make sure that between the boiler and the blast tube proper insulation is fitted.

Packaging (only burner)

	X	Y	Z	kg
BLU 15000.1	2140	2820	1960	
BLU 18000.1	2140	2820	1960	

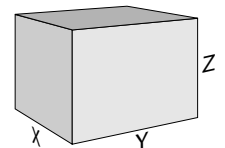

GAS OPERATING MODE - GENERAL SAFETY FUNCTIONS

START-UP MODE

As soon as the furnace system is required to supply heat, the burner control circuit will close and the program flow started. When the program has come to its end, the burner will be turned on.

An automatic test is made for the tightness of the gas valves prior to each burner start. The air damper is in its closed position when the burner is out of operation.

The electric actuator will open the closed air damper to its full-load position so that the burner will ventilate the furnace and the exhaust hoods with the specified air rate.

Shortly after the pre-ventilation process has been started the lack-of-air cut-out must change over to operating position within a certain time, i.e. the minimum air pressure setting must be reached and maintained until the burner is turned off. At the end of the specified pre-ventilation time the air damper will be moved into its partial-load position in a linked control concept with the gas damper.

The ignition transformer will be started.

At the end of the pre-ignition time the ignition gas solenoid valves will be opened to allow gas to flow into the pilot burner. The ignition electrodes incorporated in the pilot burner will ignite the ignition gas. The ionization probe gives flame signal to

control box so that the safety shut-off valves will be opened.

The gas will be fed to the gas nozzles via the gas damper while combustion air is supplied by the fan.

Gas and air will be intensively mixed in the mixing unit and ignited by the pilot flame with a specified safety period (minimum furnace heat generating rate).

After the safety period has run down the pilot burner will be turned off.

Attention:

If there are shut-off dampers in the flue gas tract they must be completely open. Otherwise there will be a high danger of low-speed detonation or explosion!

GAS OPERATING MODE

After the flame has developed the load regulator will be enabled which brings the burner into its operating position.

The load regulator will now control the burner automatically between its partial-load and full-load stages. Depending on the heat demand, the electric actuator of the compound control system will be fed with the OPEN or CLOSE command via the regulator and thus increase or decrease the gas and air flow rates.

This compound control system will vary the positions of the gas control valve and air damper and thus regulate the gas flow rate in a linked concept with the air flow rate. The burner can either be controlled by a 2-stage sliding or, if a respective controller is provided, a stepless control concept.

The stepless control will allow the burner to be operated at any desired stage between its partial-load and full-load positions.

The burner will always be turned off out of its partial-load position.

The air damper will be closed when the burner is out of operation and will thus prevent cold air flowing through the burner chamber, heat exchanger and chimney.

The interior cooling losses will thus be greatly minimized.

Gas control:

2-stage sliding

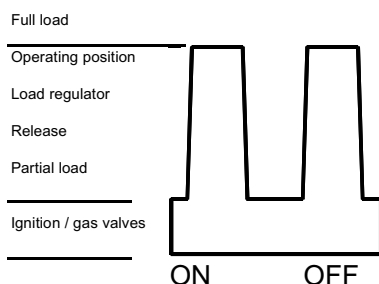

Stepless

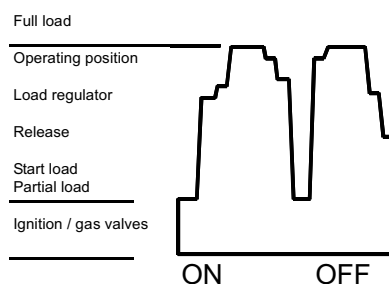

GENERAL SAFETY FUNCTIONS

In case a flame does not develop when starting the burner (fuel release) the burner will shut off at the end of the safety period (shut-off on trouble).

A shut-off on trouble will also occur in the case of flame failure during operation, air flow failure during the pre-ventilation phase and pressure failure during the whole period of burner operation.

Any failure of the flame signal at the end of the safety period and a flame signal during

the pre-ventilation phase (external light control) will result in a shut-off on trouble with the control box being locked.

The trouble is indicated by the trouble signal lamp lighting up.

The control box can be unlocked immediately after a shut-off on trouble by pressing the unlocking key. The program unit will return to its starting position and proceed with the restart of the burner.

A voltage failure will result in a regular shut-off of the burner. Upon voltage

recovery there may be an automatic restart unless another interlock is provided, e.g. by the safety system. In any case of trouble the fuel oil supply will be shut off right away. The program unit will stop at the same time causing also the trouble location indicator to stop.

The symbols will indicate the kind of trouble.

INSTALLATION

Fitting the burner to the boiler



WARNING: handling and moving operations must be carried out by specialised personnel. Use the eyebolts to lift the burner in order that it will not overturn and fall down.

To perform the installation of the burner into the boiler drill the boiler plate according to the dimension given on this manual and place the burner towards it by lifting and moving the burner by means of eyebolts.

Place the gasket on the burner flange and install the burner into the boiler by fixing nuts into the bolts. The space between the blast tube and the boiler lining must be sealed with appropriate insulating material.

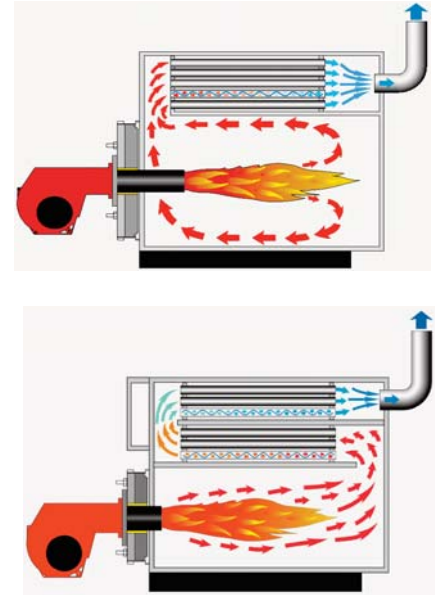
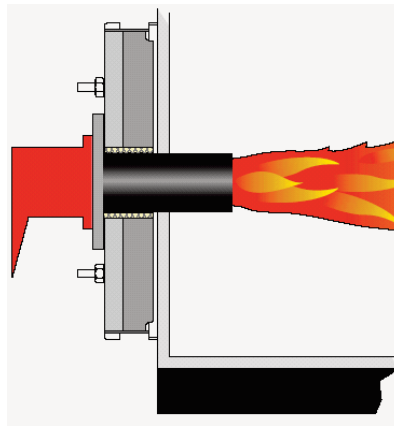

BURNER LINING

Check before burner installation:

1. Depending on the type of boiler (reverse flame or three pass) check the burner blast tube installation depth according to the data specified by the boiler manufacturer or consult the burner producer.
2. Check the ignition electrodes on the burner head as per factory setting (see figures). The setting of the mixing and ignition unit according to the boiler output will be performed during commissioning procedure.
3. Check that the head is preset at 50%.

Position of the electrodes

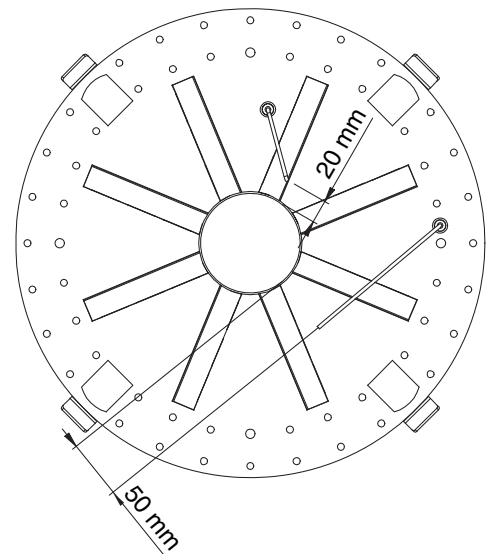
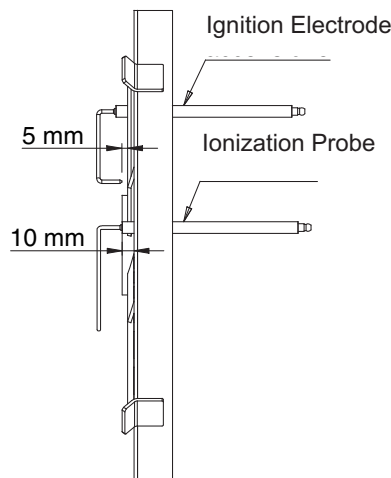

MAIN SWITCH

0 - OFF

1 - ON



INSTALLATION

Gas line

CONNECTION DIAGRAM FOR BURNERS WITH SEPARATE PILOT (GAS TRAIN LANDIS VGD...)

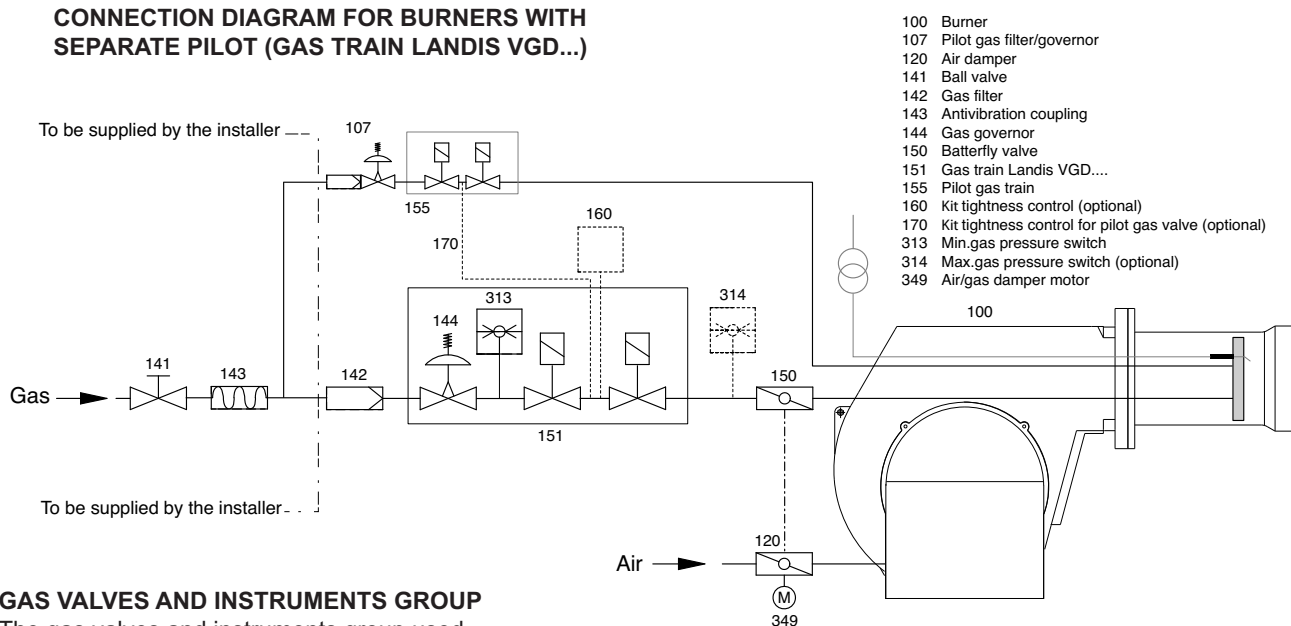

GAS VALVES AND INSTRUMENTS GROUP

The gas valves and instruments group used with the furnace will be selected according to the specific requirements to be met by a burner system.

The following factors must be taken into account:

- burner output
- furnace back pressure
- gas pressure loss of the burner head
- gas pressure losses of the gas valves and instruments group

NOTE: Only gas trains assembled by the burner manufacturer and approved in accordance with the burner test specifications. EN676 compulsory kit and accessories in order to comply to the safety regulations. Additional accessories and kits shall be installed by the installer in accordance to the local safety regulations and codes of practise.

GAS CONNECTION PRESSURE

A minimum connection pressure must be available upstream of the burner gas valve to ensure the proper functioning of the burner.

WARNING: the total gas pressure loss must always be smaller than the available gas flow pressure.

For the installation of the valves and instruments group take care to observe the mounting instructions supplied by their manufacturers (these are packed with the equipment).

The gas line installed to the burner must be dimensioned in accordance with the throughput rate and the available pressure.

For selecting the nominal bore "DN" of the gas valves and instruments group care should be taken to observe the flue resistance of the boiler and the gas pressure loss of the burner and valves and instruments group.

GAS VALVES AND INSTRUMENTS GROUP

The gas valves and instruments group can be connected directly to the gas feed line.

Take care to observe the correct order of installation and direction of flow (arrow on housing).

Check the valves and instruments and connection pieces for absence of dirt particles and foreign matter before installation and initial operation. To provide effective conditions for start-up make sure the distance between the burner and the gas stop valve is as short as possible.

LEAK TEST

The gas line upstream of the burner gas valves and instruments group must be installed in accordance with the applicable regulations, checked for absence of leaks, vented and certified accordingly by the gas installation company. The screwed unions and flanged joints must be checked for proper tightness (by making a pressure test). The leak test must be made under pressure using approved foaming agents which do not cause corrosion. For steam boiler furnaces the result of the leak test must be duly certified.

VENTING

Prior to taking the burner into operation or after any repair work make sure to vent the complete gas feed line and the gas valves and instruments group into the open atmosphere (e.g. by means of a hose) taking care to avoid any hazards.

In no case should the gas line be vented into the heating or furnace chambers. Make use of a test burner to check the gas-carrying spaces are free from an inflammable gas mixture.

SUPPORT

The valves and instruments group must be supported with a telescopic jacking member or similar during and after installation (e.g. on filter and valve).

JOINT

It is recommended to provide an easy to disconnect joint (with planar sealing faces) to facilitate repair work on the boiler (furnace) and allow the boiler door to be swivelled out if required.

INSTALLATION

Pilot gas train, kit and accessories connection - head loss diagram

PILOT GAS TRAIN CONNECTION

The pilot gas train is already installed to the burner and shall be connected to the main gas supply line preferably with flexible pipe. The pilot gas train is composed of n° 2 safety valves and n°1 gas governor and filter. Max inlet pressure 1 bar.

WARNING: Pilot gas train must be connected according to the drawing of the gas line.

GAS VALVES ADJUSTMENT

Note : the pilot valves are pre-adjusted in the factory. To increase or reduce the gas flow act on the gas governor.

GAS GOVERNOR ADJUSTMENT

The gas governor, with built-in filter, must be installed so as to stabilise the outlet gas pressure and to avoid that eventual impurities reach the gas valve. To increase gas pressure, remove the cover of governor and turn screw C. Unscrew screw C to reduce pressure, then fit the cover.

Note: the inlet gas pressure must not be higher than the specified max. gas pressure.

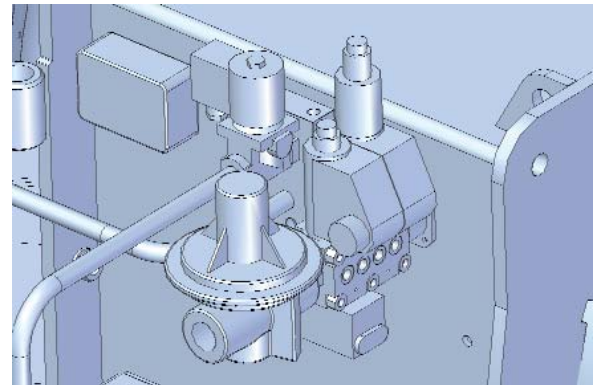
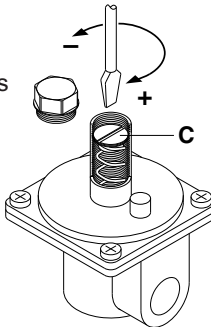

KITTC- Tightness control

Tightness control is provided as a kit and shall be assembled into the main gas train according to the instructions of the gas train separate manual.



KITPRES... Maximum pressure switch assembly

Maximum pressure switch is provided as a kit and shall be assembled into the main gas train according to the instructions of the gas train separate manual.

KITMD-RWF40 PID regulator

All progressive burner can be turned modulation with the installation of the PID that regulates the output combined with a probe.

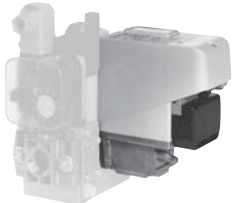
Tightness control	Modulation Kit	Max Pressure switch
KITTC- Model	KITMD-RWF40	KITPRES50
Compulsory > 1200 kW	Probe-...	KITPRES150





PRESSURE LOSS DIAGRAM: combustion head - platform 710

The diagram provides combustion head the pressure loss. To have pressure loss combined with the different type of gas train you must refer to the pressure loss diagrams.

WARNING:

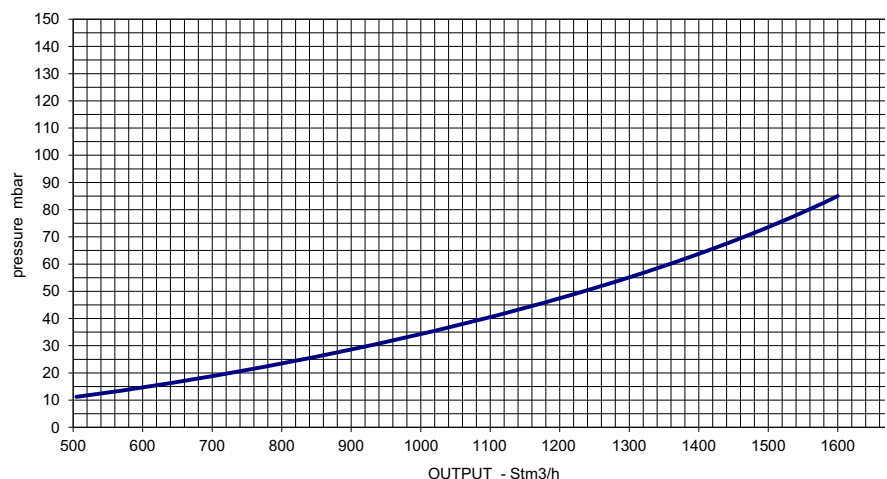
Note that the head loss diagram is only indicative and does vary depending on the setting of the head.



INSTALLATION

Gas pressure loss diagrams

! PRESSURE DROP includes: "COMBUSTION HEAD + GAS TRAIN + GAS GOVERNOR & FILTER" as per EN676 Standard. Back pressure of boiler (or other applications) must be added/included in order to have the total min pressure drop.

Burner	Gas train	Advisable gas governor & filter	Spring color	Inlet gas pressure MIN [mbar]	Inlet gas pressure MAX [mbar]	Diagram
BLU 15000.1 PR MULTICALOR 1500.1 MULTIFLAM 1500.1	VGD 40.125	no	yellow	140	700	9C
		FILTER DN 125		150	700	
	VGD 40.100	no	yellow	190	700	
		FILTER DN 100		230	700	
	VGD 40.080	no	yellow	380	700	
		FILTER DN 80		450	700	

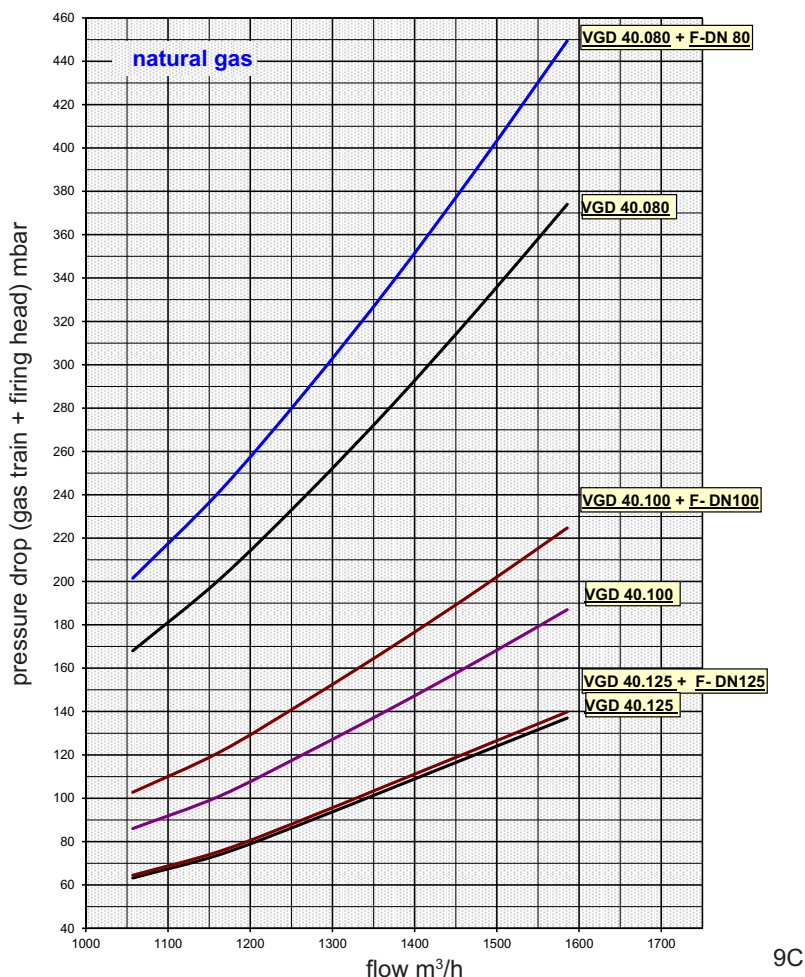

LEGENDA

- Pf: Back pressure of furnace
- Pb: Pressure of burner (combustion head + complete gas train)
- Pin: Minimum inlet pressure

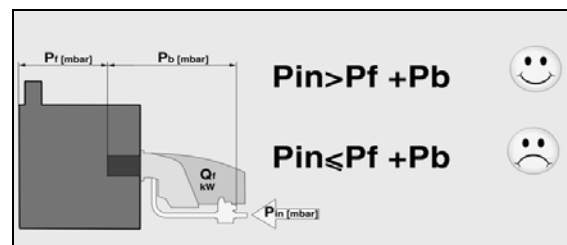

INSTALLATION

Gas pressure loss diagrams

! PRESSURE DROP includes: "COMBUSTION HEAD + GAS TRAIN + GAS GOVERNOR & FILTER" as per EN676 Standard. Back pressure of boiler (or other applications) must be added/included in order to have the total min pressure drop.

Burner	Gas train	Advisable gas governor & filter	Spring color	Inlet gas pressure MIN [mbar]	Inlet gas pressure MAX [mbar]	Diagram
BLU 18000.1 PR MULTICALOR 1800.1 MULTIFLAM 1800.1	VGD 40.125	no	yellow - red	200	700	10C
		FILTER DN 125		210	700	
	VGD 40.100	no	yellow - red	270	700	
		FILTER DN 100		330	700	
	VGD 40.080	no	yellow - red	540	700	
		FILTER DN 80		650	700	

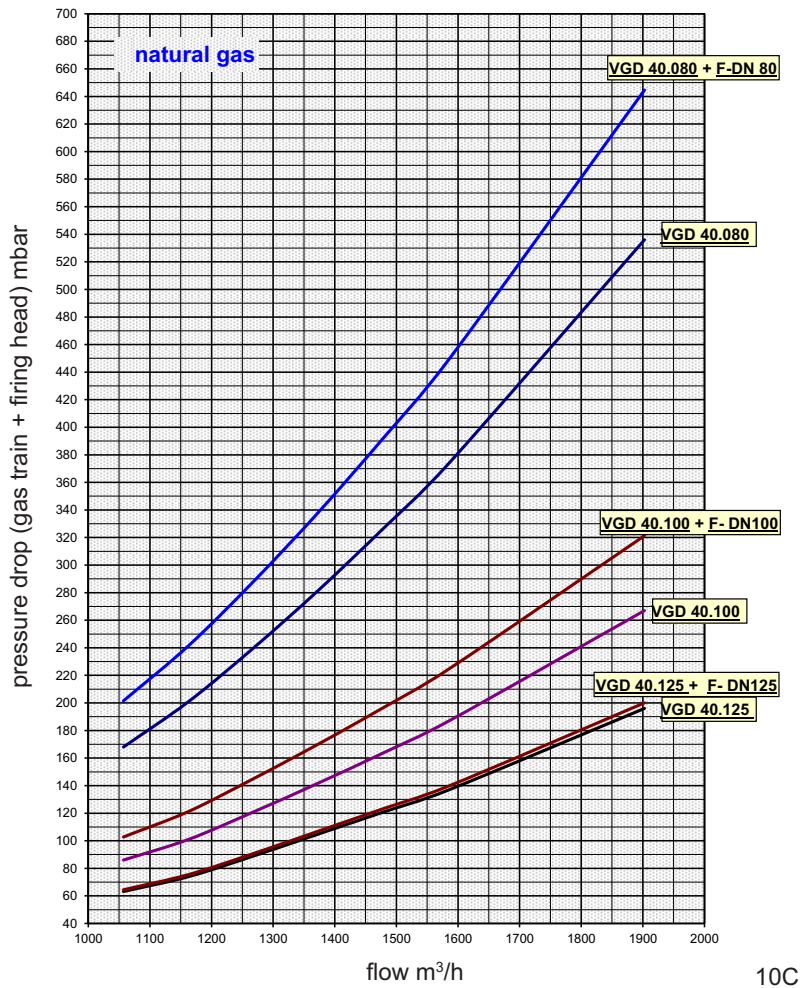

LEGENDA

Pf: Back pressure of furnace
 Pb: Pressure of burner (combustion head + complete gas train)
 Pin: Minimum inlet pressure

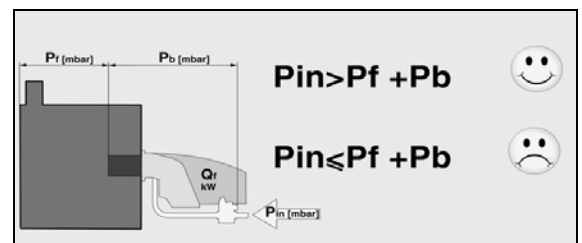

INSTALLATION

Electrical connections

! **WARNING:** Electrical wiring must be carried out with electrical supply disconnected and with burner switch in position OFF. Electrical supply must correspond to the one shown on the burner label.

APPLICABLE STANDARD

The electrical connection work comprising all the installation materials, terminals and earth connections must be carried out in accordance with the applicable regulations. For the electrical installation of the burner care must be taken to observe the circuit diagram made out for the furnace system.

The electrical connection of the burner and gas valves and instruments shall be entrusted to authorized specialists only.

NOTE: For the installation of the connection cables care must be taken to provide cable loops of sufficient length to allow for the swing-out of the boiler door and burner.

Make sure after the completion of the electrical connection work to check the wiring of the electrical system of the burner. This should include a check of the direction of rotation of the burner motor (fan).

GENERAL WARNINGS:

All applicable electrical safety regulations must be followed. Failure to correctly dimension the suitable input power and earth the equipment may cause damages to person and compromise the correct function of the burner therefore the electrical system shall be checked by qualified personnel.

The manufacturer declines all responsibility for modifications or connections different from those shown in the electrical scheme.

Adapters, multiple plugs and extension cables may not be used for the equipment's power supply.

An omnipolar switch in accordance with current safety regulations is required for the mains supply connection.

ELECTRICAL CONNECTION

1) of the burner

- Built-in electrical cabinet

Use cable gland in order to secure the required level of protection. All the links, power and control, are connected to the terminal block of the cabinet. Provide cables in sufficient length to secure the rotation of the burner body according to the assembly.

Check and adjust the size of the contactors and thermal relays and the wires section according to the motor and supply voltage specs.

ATTENTION: Wiring is not supplied.

2) of the gas train

- Connect the plugs pending to the valve: either on the cabinet, or on the coupling case on the body of the burner.

PROBES CONNECTION

ACTIVE PROBE CONNECTION (FOR MODULATING VERSION)

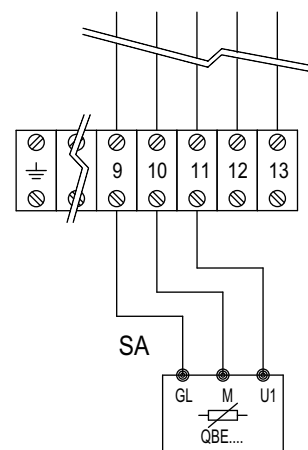

PASSIVE PROBE CONNECTION (FOR MODULATING VERSION)

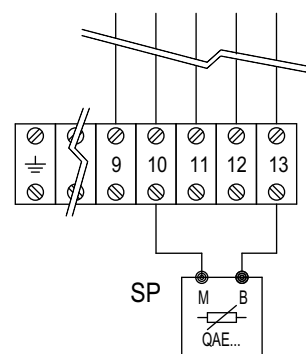

LEGENDA

HLB: lock-out lamp
 STAB: two stages thermostat
 HLF: burner on flame lamp
 STC: boiler thermostat
 STS: safety thermostat
 SA: active probe
 SP: passive probe

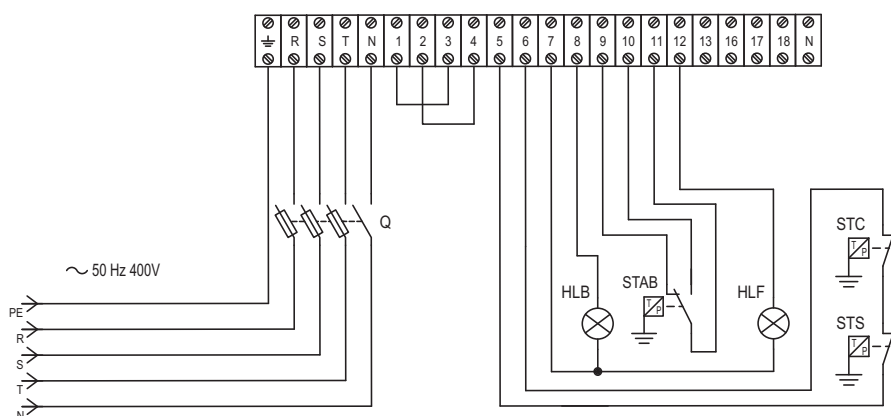

START-UP: CHECKING PROCEDURE

CHECKS BEFORE COMMISSIONING:

- That the burner is assembled in accordance with the instructions given here.
- Setting the combustion components.
- All electrical connections must be correct.
- Check the burner motor for correct direction of rotation.
- The heat generator must be ready for operation, and the operating regulations for the heat generator must be observed.
- The heat generator and heating system must be filled with water and the circulating pumps must be in operation.
- The temperature regulator, pressure regulator, low water detectors and any other safety or limiting devices that might be fitted must be connected and operational.
- The exhaust gas duct must be unobstructed and the secondary air system, if available, must be operational.
- An adequate supply of fresh air must be guaranteed.
- Make a test of the all gas-carrying elements for absence of leaks.
- With burner in starting position check that air damper is in "CLOSED" position.
- Check that control box is unlocked and in its original position.
- A standard-compliant measuring point must be available, the exhaust gas duct up to the measuring point must be free of leaks to prevent anomalies in the measurement results.

GAS START-UP

- Connect the measuring instruments for the gas head pressure on the test connection downstream of the gas damper and the air pressure on the burner test connection.
- Open the gas shut-off valve before the gas-armatures and test the gas pressure on the pressure gauge
- Set the "Manual-Automatic" selector switch to "Manual".

If the gas valves are tested for absence of leaks, this should be continued until a positive result is obtained. If a valve is found to leak, the program will not step forward to the control box. The burner will start according to the program flow of the control box.

Prior to the initial fuel feed start make a functional test of the burner program flow:

Gas system:

- Shortly open the gas shut-off valve before the gas train until pressure is available and close again.
- Start burner and check program flow for correct start-up sequence:
 1. Fan.
 2. Pre-ventilation damper.
 3. Check air pressure.
 4. Partial-load damper.
 5. Ignition.
 6. Valves open.
 7. Shut-off upon trouble after expiry of safety period (see control box) or shut-off because of gas supply failure.
 7. The burner will either stop as the gas valves open (due to gas pressure decrease) or lock out at the end of the safety time.
- Unlock the control box.

EXHAUST GAS TEST

To ensure an economically efficient and trouble-free operation of the system it will be necessary to adjust the burner specifically in accordance with the furnace system. This is achieved by means of a fuel-combustion air compound control unit which adjusts the burner to ensure a proper combustion. Exhaust gas tests are required for this purpose.

The percentage CO₂ and O₂ and the exhaust gas temperature will have to be measured to determine the efficiency and combustion quality.

Prior to any measurement make sure to check the boiler and exhaust gas system for absence of leaks.

Secondary air will falsify the measured results

Check that the exhaust gases have a residual oxygen (O₂) content as low as possible and a carbon dioxide (CO₂) content as high as possible.

The carbon monoxide content of the exhaust gases must be below the currently applicable specifications in all load stages. In the fuel oil combustion mode the permissible soot number in the exhaust gas is not allowed to be exceeded

DETERMINING THE VOLUMETRIC GAS FLOW RATE

The thermal furnace output of a boiler (Q_F) is the amount of heat supplied with the gas in a unit of time.

When taking the burner into operation the volumetric fuel flow rate should be selected according to the nominal thermal capacity of the boiler.

Example:

Nom. thermal output	Q _N	1000 kW
Boiler efficiency	n _K	0,88
Calorific value of gas	H _U	9,1 kWh/m ³
Gas pressure	p _U	100 mbar
Barometer reading	p _{amb}	980 mbar
Gas temperature relative	t _{gas}	15°C
Gas temperature absolute	T	(t _{gas} +273)
Standard atmospheric pressure	p _n	1013 mbar

$$Q_F = \frac{Q_N}{n_K} = \frac{1000}{0,88} = 1136 \text{ kW}$$

Volumetric gas flow rate at STP:

$$v_{Bn} = \frac{Q_N}{H_U \cdot n_K} = \frac{1000}{9,1 \cdot 0,88} = 125 \text{ m}^3/\text{h}$$

Volumetric gas flow rate in operating condition:

$$v_{BB} = v_{Bn} \frac{T}{273} = \frac{p_n}{p_{amb} + p_u} =$$

$$= 125 \frac{273+15}{273} \frac{1013,25}{980+100} = 123,9 \text{ m}^3/\text{h}$$

Recommended combustion parameters

Fuel	Recommended (%) CO ₂	Recommended (%) O ₂
Natural gas	10 ÷ 9	3,1 ÷ 4,8
Light oil	13 ÷ 11,5	3,3 ÷ 5,3
Heavy oil	12,5 ÷ 11	4,2 ÷ 6,2

WARNING: if the installation is above sea level the output of the burner vary base on the diagram.

The regulation of the burner in this case shall take into account the reduced power of the burner due to the missing air.

Ratio between O₂- and CO₂-
for natural gas H (CO₂max = 11,7%)

Ratio between O₂- and CO₂-
for light oil EL (CO₂max = 15,40%)

Ratio between O₂- and CO₂-
for heavy oil S (CO₂max = 15,60%)

$$O_2 = 21 \frac{CO_2\text{max} - CO_2\text{gem}}{CO_2\text{max}} = \%$$

CO₂ gem = % CO₂ measured on dry flue gases

Mean air pressure vs. altitude above sea-level

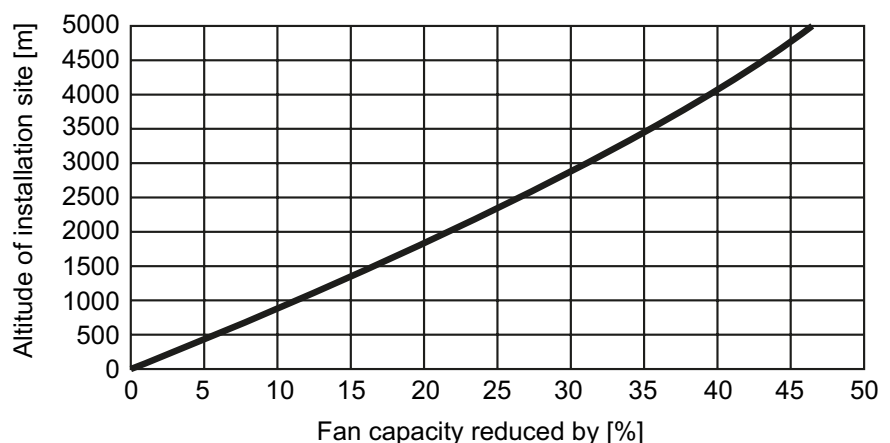

START-UP

Select the gas operation in order to proceed with start up on the gas side. On the selector put the operation on minimum capacity.

MAIN SWITCH

0 - OFF

1 - ON

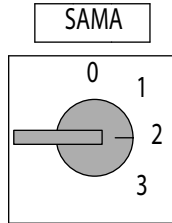
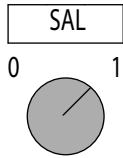

0=STOP
1=UP
2=LOW
3=AUTO

0 : operating elements locked in an intermediate position.

1 : operation on maximum capacity

2 : operation on minimum capacity

3 : automatic operation



KMV contactor: check the air fan motor rotation. If not correct invert the two phases on the power supply.



KMV

START UP THE BURNER

The control box starts the pre-purge cycle, the fan motor and opens the air flaps in full open position.

At the end of pre-purging, the control box drives the servomotor into the ignition position and starts the ignition transformer.

After a few seconds the control box opens the pilot valves and starts the pilot flame.

After the flame stabilisation the control box opens the main valves and the burner goes in the low flame and the pilot switch off.

In case of faulty ignition, the control box switches the burner into safety condition, in such a case you must rearm the burner.

Gradually go step by step using the selector on position 0 to stop the flame, from the low flame to the high flame in order to have a stable flame.

The flame stabilisation can be achieved by adjusting the gas flow on the gas train (REFER TO THE GAS TRAIN MANUAL)

When the servomotor arrive at 90° you have completed first tuning of air and gas flow according to the boiler capacity required.

Check the combustion values throughout servomotor stroke.

Adjusting the maximum air flow rate

In order to adjust the maximum air flow rate see figure with selector in maximum operation. Loosen the nut holding the air damper transmission rod and correct air flow till you reach the combustion values suggested by reading the value on the combustion analyser. If you do not reach acceptable air flow rate you shall adjust the firing head. Move the head forward to increase air flow backwards to reduce.

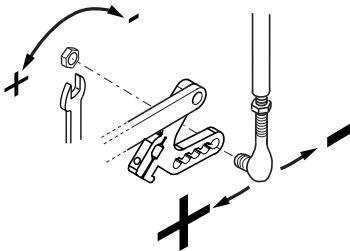

Firing head setting

The firing head is pre-adjusted at the 50% from the factory. The setting fully open enables to reach the full power of the burner and full close to reach the minimum power of the burner.

The optimal position depends on the output that we need to reach but the default setting shall be

modified only when you are not able to reach the suggested combustion value by adjusting the air flow in the maximum flame.

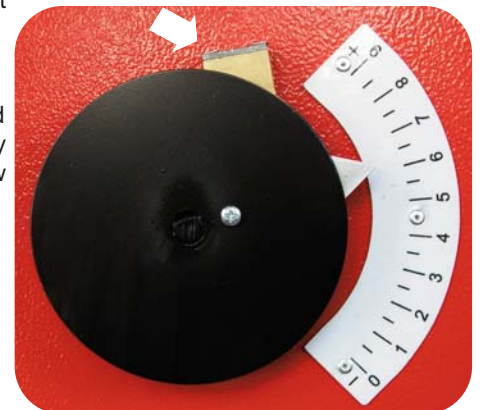

Servomotor SQM50 - Air damper motor pre-setting

The cams of the servomotor are set from the factory in order to start the burner and reach the maximum output.

The following setting are the standard one:

I. High flame position 90°

II. Air flap position in standby 0°

III. Ignition position gas 10°

IV. Low flame position gas 15° (can be modified depending on the minimum output of the boiler)

V. To VIII not used

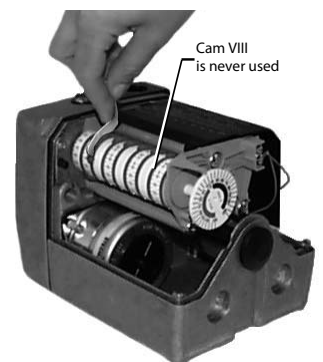

START-UP

Adjusting the intermediate burner capacity

In order to adjust intermediate capacity of the burner use the selector on position 0 to stop the stroke and regulate the cam on the different screw position. The adjustment shall be done according to the drawing in order to have the correct combustion value in each points "+/-" switch (different screw positions). Using a suitable Allen wrench, change the position of the cam guide blade; if you screw it down, the flow rate is reduced; if you unscrew it, the flow rate increases.

WARNING: the variable profile of the cam shall have a normal proportional curvature in order to have good combustion values and reduce its mechanical stress breakdown.

Point to point gas cam configuration

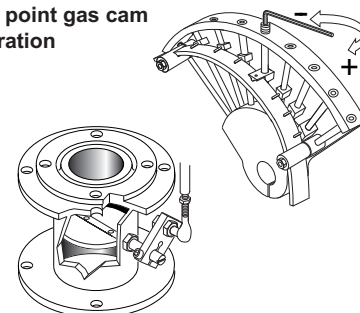

Pressure switch adjustment

AIR PRESSURE SWITCH CALIBRATION

The air pressure switch is provided for monitoring the pressure of the combustion air fan. Unscrew screws A and B and remove cover C.

After the air and gas setting you have to calibrate the air switch with the burner working on the low flame by slowly turning the relative knob clockwise until the burner locks out. Read the value and then decrease it by 15%.

Set the pressure switch to the minimum by turning knob D to position 1.

Start the burner and keep in low flame running, while checking that combustion is correct. Through a small cardboard, progressively obstruct the air intake until to obtain a CO₂ increase of 0,5±0,8% or else, if a pressure gauge is available, connected to pressure port E, until reaching a pressure drop of 1 mbar (10 mm of W.G.).

Slowly increase the adjustment value of the air pressure switch until to have the burner lockout. Remove the obstruction from the air intake, screw on the cover C and start the burner by pressing the control box rearm button.

WARNING: the air pressure switch shall prevent the air pressure to go below 80% from the adjustment value in order to prevent the CO in the fumes to exceed 1% (10000 ppm). Using the analyser try to close the air inlet and check that the burner locks out before exceeding CO value of 1% in the fumes.

MIN GAS PRESSURE SWITCH

The gas pressure switch has the function to check that the gas pressure before the gas valve does have the minimum pressure to make the burner running correctly.

Unscrew off and remove cover M. - Set knob N to a value equal to 60% of gas nominal feed pressure (i.e. for natural gas nom. pressure = 20 mbar, set knob to a value of 12 mbar; for LPG nom. pressure of G30/G31- 30/37 mbar, set knob to a value of 18 mbar).

MAX GAS PRESSURE SWITCH (KIT)

The maximum gas pressure switch has the function to check that the gas pressure after the gas train and before the head does not exceed the pre-set limits.

Max gas pressure switch: it is available as a kit for different pressure.

Air pressure switch

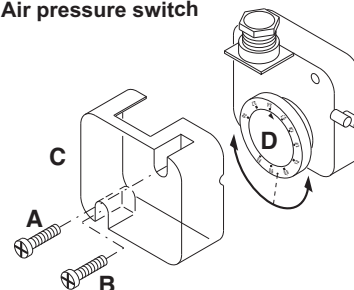

Gas pressure switch

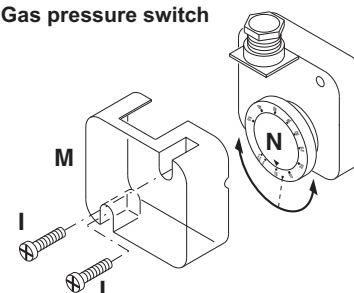

Servomotor SQM50 - Final setting

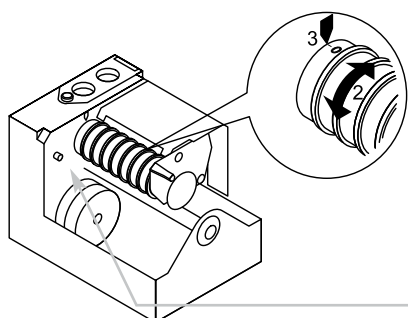

Once the point to point gas cam setting has been completed we need to set the final minimum output of the burner using the servomotor cam IV (low flame gas). Using the suitable key regulate the grades "+/-" switch). The low flame position must be higher than the ignition position cam on the servomotor. Turn the burner off and start it again in order to check if the burner start properly otherwise adjust the ignition gas cam number III.

GAS SETTING ENDED: switch the selector to automatic position.



WARNING: Do not use the button cam drum release button.

MAINTENANCE PROGRAM

! Burner and boiler servicing must only be carried out by authorised and qualified personnel at least once a year. Depending on the type of installation, shorter maintenance intervals may be necessary. The system operator is advised to take out a maintenance contract to guarantee regular servicing.
WARNING: Use original spare parts.

SAFETY WARNINGS:

1. Turn off the power supply and protect the system from accidental start-up
2. Cut gas supply
3. Make sure there is no residual power in the system and that the actions in points 1 and 2 have been completed
4. Before opening the burner casing, ensure that the fan motor has stopped completely

Failure to observe any of these instructions will result in the risk of death or injury!

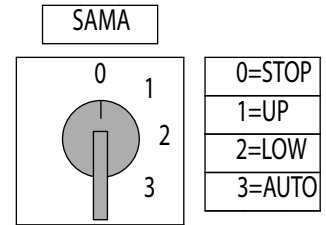

WORKS RECOMMENDED AS PART OF ANNUAL BURNER MAINTENANCE:

- Emergency stop button function check
- Check burner start characteristics
- Run burner test and input measurement in the boiler room
- Clean the combustion components and replace defective parts if necessary
- Check the combustion head components and make sure that all components are in good condition otherwise replace them
- Replace ignition electrodes if necessary and check their correct position after any intervention
- Flame monitor and automatic combustion control unit function check
- Clean the fan wheel and the housing and grease rotating parts if necessary
- Perform visual inspection of gas lines in the boiler room and check the gas flow
- Clean the gas filter cartridge with air periodically, replace it if necessary
- After the cleaning of the components of the gas train perform the leakage test
- Make visual inspection of the burner's electrical components and eliminate malfunctions if necessary
- Burner safety devices function check (air pressure/gas pressure switches)
- Commissioning the burner and correct the adjustment values if necessary

NOTES ON REASSEMBLING: Perform the described step in reverse order and make sure to refit components as they were originally assembled and the system is free from leaks. Use only original spare parts.

DRAW UP A MEASUREMENT REPORT ACCORDING TO THE LOCAL REGULATION AND CODES OF PRACTISE OF THE COUNTRY

EXHAUST GAS LOSS

Exhaust gas loss by way of free heat will occur as a result of the temperature difference between the fuel-air mixture entering the furnace chamber and the gases discharged. Any increase in the excess of air and the resultant higher exhaust gas volume will cause the exhaust gas loss to rise. The exhaust gas loss can be calculated as follows:

$$q_A = (t_A - t_L) \frac{A_1}{CO_2} + B$$

- q_A = exhaust gas loss [%]
- t_A = exhaust gas temperature [°C]
- t_L = combustion air temperature [°C]
- CO_2 = volumetric content of carbon dioxide [%]

	Light oil EL	Heavy oil S	Natural gas	Town gas	LPG
A1	0,50	0,490	0,370	0,350	0,420
B	0,007	0,007	0,009	0,011	0,008

Example

Data measured in natural gas mode:
 CO₂ content of exhaust gases: 10,8%
 Exhaust gas temperature: 195°C
 Air intake temperature: 22°C

The exhaust gas loss can be calculated as follows:

$$q_{Af} = (195-22) \left(\frac{0,37}{10,8} + 0,009 \right) = 7,48\%$$

Data measured in fuel oil mode:
 CO₂ content of exhaust gases: 12,8%
 Exhaust gas temperature: 195°C
 Air intake temperature: 22°C

The exhaust gas loss can be calculated as follows:

$$q_{Af} = (195-22) \left(\frac{0,49}{12,8} + 0,007 \right) = 7,83\%$$

MAINTENANCE PROGRAM

REMOVING THE FIRING HEAD AND BLAST TUBE

WARNING !

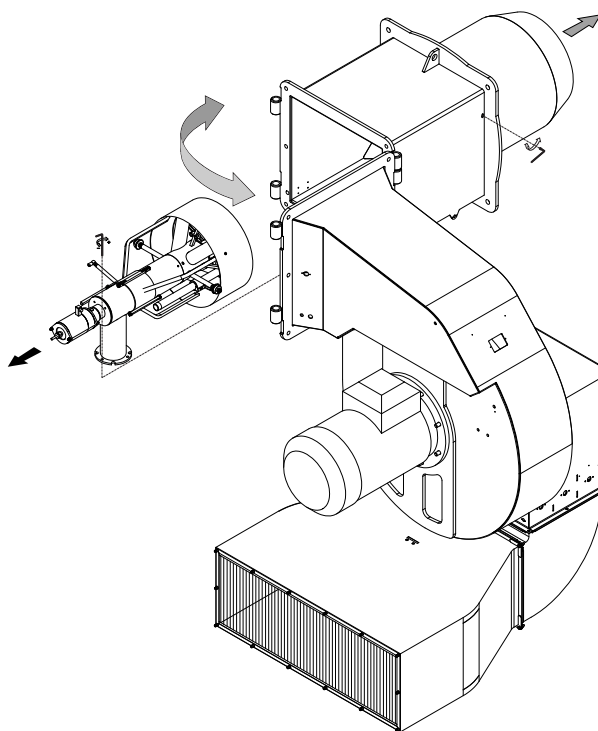
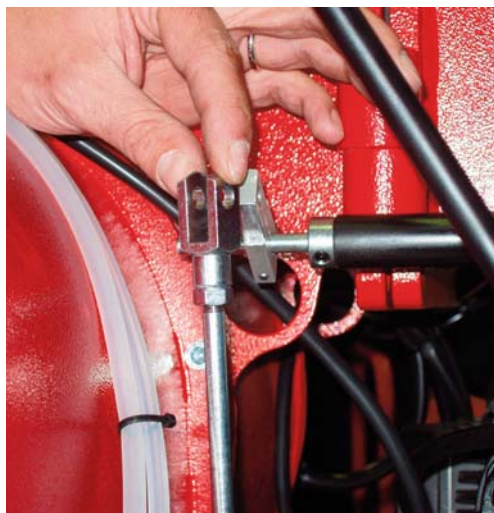

POSITION OF ELECTRODES

ATTENTION:

Check the position of the electrodes after any intervention as wrong position could cause ignition troubles.

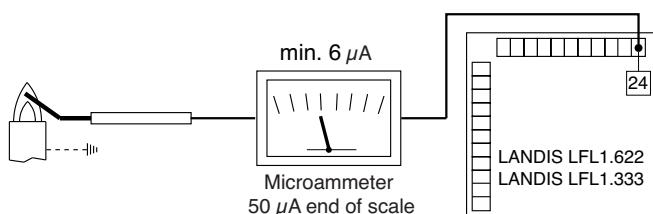
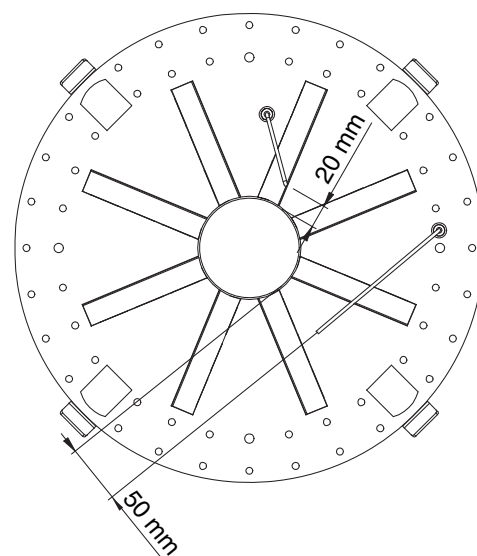
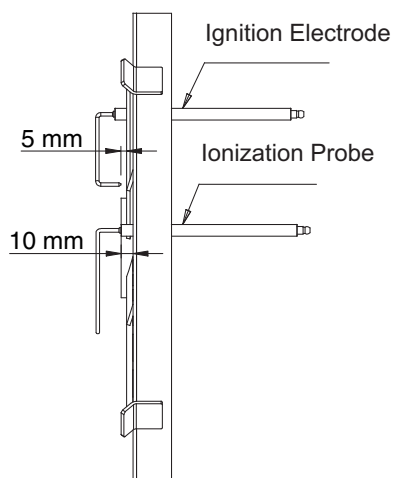

The ionization current is checked by inserting a microammeter with an end scale of 50 μA (d.c.) in series with the ionization probe. A faulty position of the electrode can lead to a reduction in the ionization current and cause a safety shut off of the burner due to a flame detection failure. In this case, check the position of the electrode, its electric connection and the earthing of the burner. The ionization current is normally $> 20 \mu\text{A}$.

GAS FILTER CLEANING - GAS PILOT FILTER CLEANING

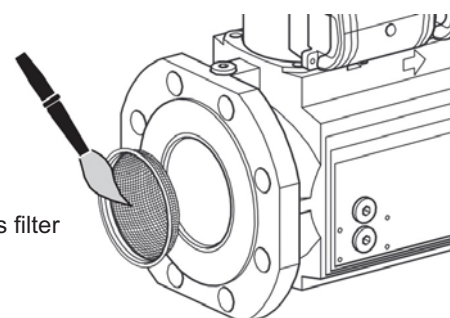

Check and clean the gas filter in the pilot gas valve

TROUBLESHOOTING INSTRUCTIONS

The list of faults/causes/possible solutions for a set of main failures is a guideline for professional personell authorised to carry out service and maintenance.

Irregular burner operation or malfunction: check that every adjustment parameter is correctly set as per instruction on this manual.

TROUBLESHOOTING TABLE GAS OPERATION			Burner doesn't start	Burner starts with continuous pre-purge	Burner starts and then goes into lock-out	Pilot Ignition failure (1st safety time)	Main Ignition failure (2nd safety time)	Burner lock-out after flame appearance / pulsation	Flame control repeats the cycle and does not give consent	Combustion emission not satisfactory	Burner doesn't switch into Hi flame	Burner lock-out during operation	LFL MULTICALOR MULTIFLAM BLU
STATUS	CAUSES	REMEDIES											
PRE-START (MISSING SIGNALS)	Defective control box unit	Replace control box unit	X		X	X	X	X	X		X	X	YES
	No electrical power supply Wrong electrical connections	Check switches/contactors Check connections	X										YES
	Air pressure switch not "closed"	Check contacts	X										YES
	Boiler thermostats open	Check contacts	X										YES
	Fan motor overload intervention	Replace Fuse	X										YES
	Auxiliaries fuses interrupted	Replace Fuse	X										YES
	Servomotor [CLOSE] position switch not reach	Check servomotor settings	X										YES
	Minimum gas pressure switch not close	Open manual ball valve, check pressure switch settings, contacts, replace if necessary	X										
LEAKAGE CHECK	Leakage test successful - signals not arrive to control unit	Check contacts	X										YES
	Leakage Test failure (VPS / VDK)	Clean valves or replace leakage controller if necessary	X										YES
	Leakage Test failure (LDU kit)	Check contacts, clean valves or replace leakage controller if necessary	X										YES
SEQUENCE START	Servomotor [OPEN] position switch not reach	Check servomotor settings		X									YES
	Servomotor [MIN] position switch not reach	Check servomotor settings		X									YES
	Extraneous light	Eliminate light source			X								YES
LACK OF AIR	Air pressure switch fail to connect to Terminal 14	Check contacts			X								YES
	Fan contaminated / dirty	Clean fan			X					X		X	YES
	Fan motor rotation direction not correct	Check direction and contactor			X					X		X	YES
IGNITION & FLAME STABILISATION PERIOD	Flame supervision circuit internal test failed	Replace control unit			X								YES
	Pilot flame failure - Pilot gas valves not open	Check valves contacts / replace if necessary				X							YES
	Pilot flame establish - weak flame signal	Check Ionisation or flame sensor Replace if necessary				X							YES
	Ignition transformer faulty	Replace				X	X						YES
	Ignition cable & electrodes defective	Replace				X	X						YES
	Electrode bad position	Check setting / replace if necessary				X	X						YES
	Main solenoid valve fails to open	Check contacts and clean valves Replace valves if necessary					X						YES
COMBUSTION	Flame sensor signal failure	Clean, re-position or replace if necessary			X	X	X	X				X	YES
	Head adjustment not correct	Check settings						X		X		X	YES
	Gas / Air mixture setting not correct	Check settings						X		X		X	YES
	Oscillating gas pressure	Install damping throttle (AGA 25) - order separately or reduce supply pressure						X		X		X	YES
	Capacity reduction due to lower gas supply pressure	Check gas pressure, clean filter, replace cartridge if necessary								X			YES
	Gas pressure regulator not regulating	Replace regulating valve								X			YES
	Load control device does not close	Check load control, replace if necessary									X	X	YES

OPERATING TROUBLE

In case of operating trouble it should be checked whether the system is in proper working order.

Make a check for the following:

1. Availability of fuel.

Availability of gas in the line at sufficiently high pressure.

Correct position of fuel selector switch.

2. Availability of electric power in the burner system.

3. Proper functional order and setting of all control and safety instruments such as

temperature controller, safety limiter, water failure cut-out, electrical limit switches, etc. If the trouble is not found to be due to any of the above-mentioned points it will be necessary to test the burner functions very carefully.

Prevailing conditions:

The burner will be found to be out of operation and in faulty and interlocked position.

Proceed with searching for the cause of the trouble and eliminate it. Unlock the

control box by pressing the fault eliminate key and start the burner.

Do not press the fault eliminate key longer than 10 seconds.

The start-up program will be initiated and should be carefully monitored.

The possible cause of the fault may be quickly found by reference to the fault indicator of the control box and watching the start-up and operating program.

Control program in the case of trouble and fault indicator LFL 1... / LGK 16...

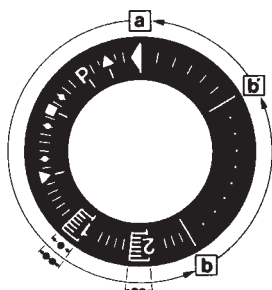

LFL 1... / LGK 16...

a-b Starting program

b-b' In a number of time versions; idle steps of the program unit to self-stop after burner start-up (b' = operating position of program unit)

b(b')-a After-flushing program after regular stop. In the starting position "a" the program unit will automatically stop or initiate an immediate restart of the burner, e.g. after a fault has been eliminated

- Duration of the safety period for single-tube burners

- Duration of the safety period for burners with ignition gas valve

Basically, any type of trouble will result in the immediate stop of the fuel supply.

At the same time, the program unit and consequently the fault indicator will stop. The type of trouble can be identified by the symbol opposite to the reading mark of the indicator:

◀ **No start**, e.g. because the "CLOSED" signal from the "Air Damper CLOSED" limit switch is missing or a contact is not closed between terminals (12) and (4) or (4) and (5); or the contacts of all control and safety units in the controlled system are not closed (e.g. gas pressure or air pressure switches, temperature or pressure regulators).

▲ **Operating stop** because the "OPEN" signal from the "Air Damper OPEN" limit switch is missing. Check and adjust the limit switch concerned.

P Shut-off on trouble because there is not air pressure signal at the beginning of the air pressure check.

Any air pressure failure after this time will also lead to a shut-off on trouble.

■ **Shut-off on trouble** because of a fault in the flame monitoring circuit.

▼ **Operating stop** because the position signal of the "Partial Load" limit switch (air damper in "Partial Load" position) is not available on terminal (8). Check and adjust the limit switch concerned.

1 Shut-off on trouble because a flame signal is not available on the expiry of the (1st) safety time.

Any failure of the flame signal on the expiry of the safety time will also lead to a shut-off on trouble.

2 Shut-off on trouble because the flame signal has not occurred on the expiry of the (2nd) safety time (flame signal of main flame with burners having an ignition gas valve).

| **Shut-off on trouble** because the flame signal failed during burner operation or a lack of air has occurred.

◀ **Shut-off on trouble** during or after the control program flow due to external light (e.g. by flame not extinguished, leaking fuel valves) or a faulty flame signal (e.g. fault in flame monitoring circuit, or similar); see flame monitor.

If the shut-off on trouble occurs at any other time between start and pre-ignition that is not identified by a symbol as above, this will normally be due to an early flame signal which is considered to be a faulty flame signal.

The control box may be unlocked immediately after a shut-off on trouble using the unlock button with integrated fault signal lamp or an external switch. After it has been unlocked (and after a defect with resultant operating stop has been eliminated and after a voltage failure), the program unit will in any case return to its starting position with voltage being only supplied to terminals 7, 9, 10 and 11 as preset by the control program. It is only at this stage that the program of the control box will restart the burner.

APPENDIX

Control box - Damper actuators

CONTROL BOX LFL 1.../LGK...

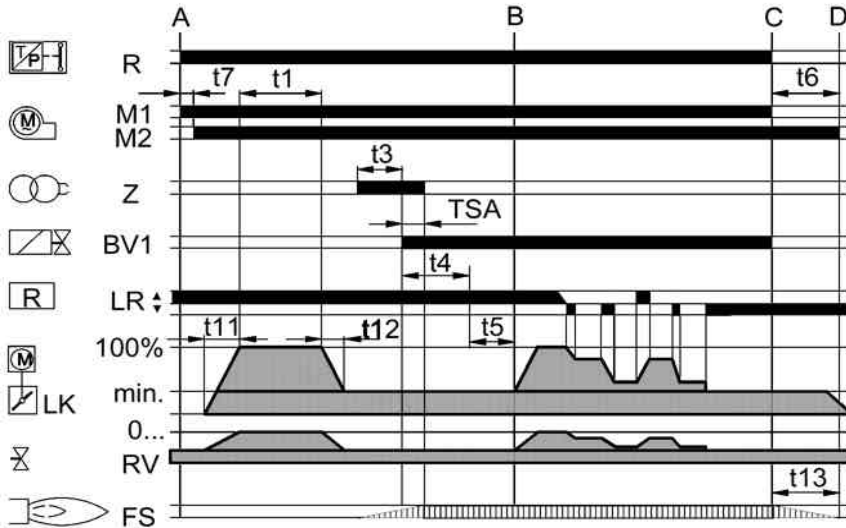

R: Temperature or pressure controller
 M: Fan motor
 Z: Ignition transformer
 BV: Fuel valve(s)

LR: Load regulator
 LK: Air damper
 RV: Steadily adjustable fuel valve
 FS: Signal of flame

The LFL 1.../LGK... type controller is designed to control and monitor burners working according to a stepwise or modulating principle. A detailed functional description with technical data and project planning information with respect to the automatic combustion controllers can be found in the annex and in the documents: LFL 1...-7451/LGK...

Functional diagram
 LFL 1.../LGK...

A: Starting type interval
 A-B: Flame development interval
 B: Burner has reached operating position
 B-C: Burner operation (heat generation)
 C-D: Regular shut-off
 t1: Pre-ventilating time
 t2: Safety time
 t3: Pre-ignition time
 t4: Fuel valve enable
 t5: Load regulator enable
 t11: "OPEN" run time of air damper
 t12: "CLOSE" run time of air damper

DAMPER ACTUATORS SQM50...

Description

The SQM actuator is intended for use with two-stage sliding or modulating oil, gas or dual-fuel burners. The reversible actuator is fitted with a synchronous motor which drives a shaft via a gearbox. The shaft end carries a coupling to drive the fuel and combustion air controlling element.

The SQM actuator has been designed for dual-wire control by controller or switching units with change-over contacts.

Potentiometers can be installed for a range of applications on customer's request.

The limit and auxiliary switches are set by means of manually adjustable latching cam plates. Scales are fitted between the disks to facilitate the selection of the switching points.

The cam plates are provided with a small pointer for indicating the switching point of a scale between the setting ranges.

An additional scale fitted to the end of the cam roller serves to indicate the position of the actuator.

The drive unit may be disconnected from the controlling element by changing over a rocker arm mounted to the gearbox.

This will allow any desired position of the controller plate to be selected by hand. Drive and output will be coupled in the vertical position of the rocker arm.

The fuel-air curve should be set over the full range of the cam plate so that operating safety will be retained also when the limit switch is overrun.

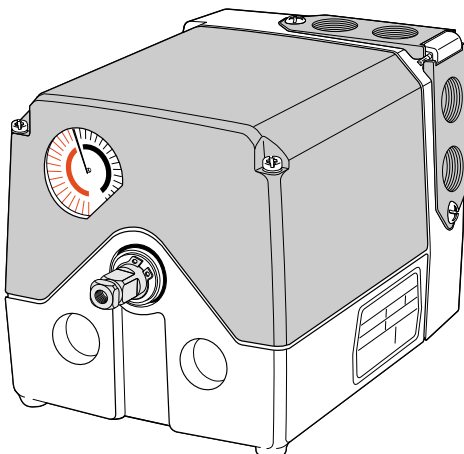

APPENDIX

Electrical diagrams

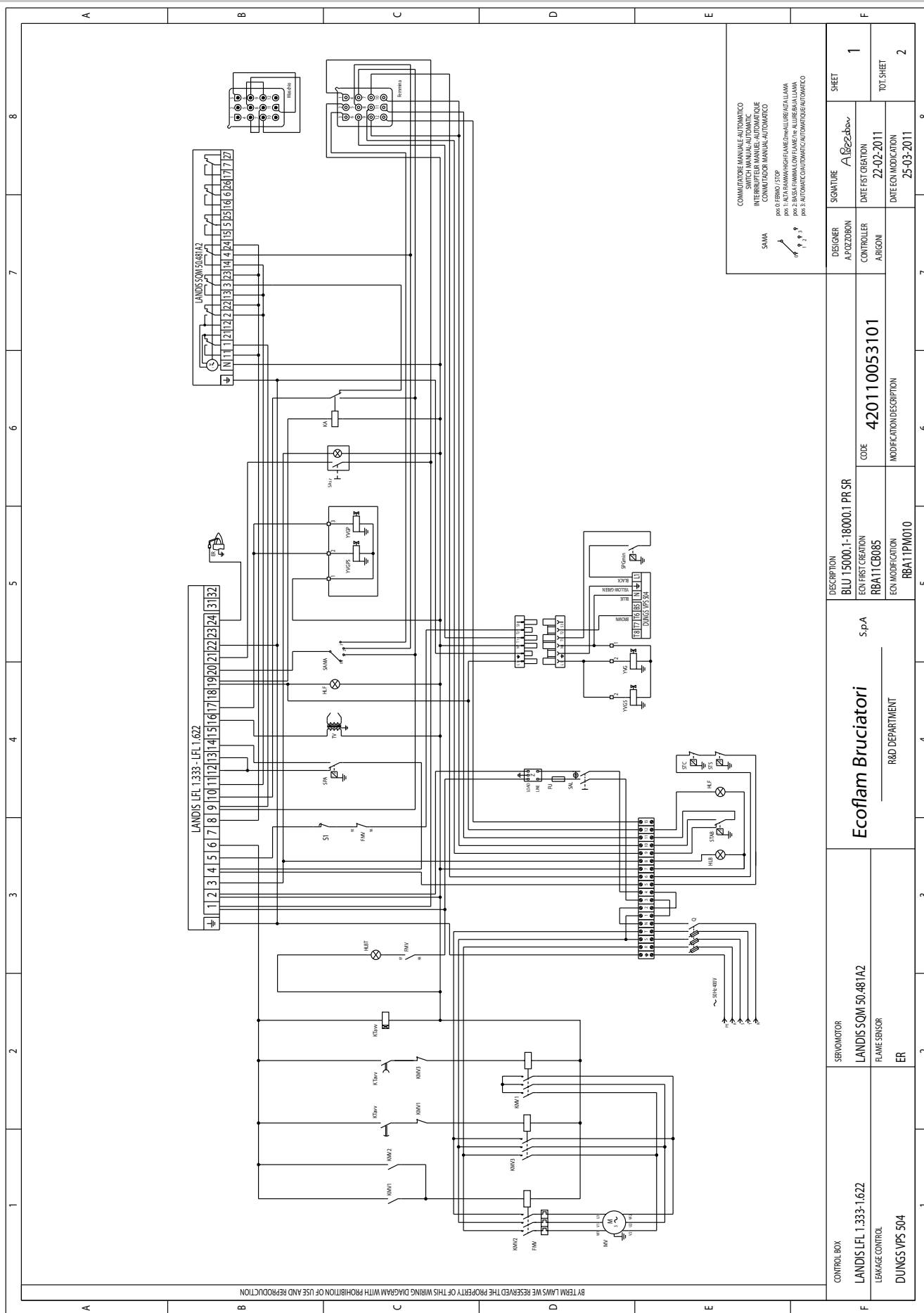

APPENDIX

Spare parts

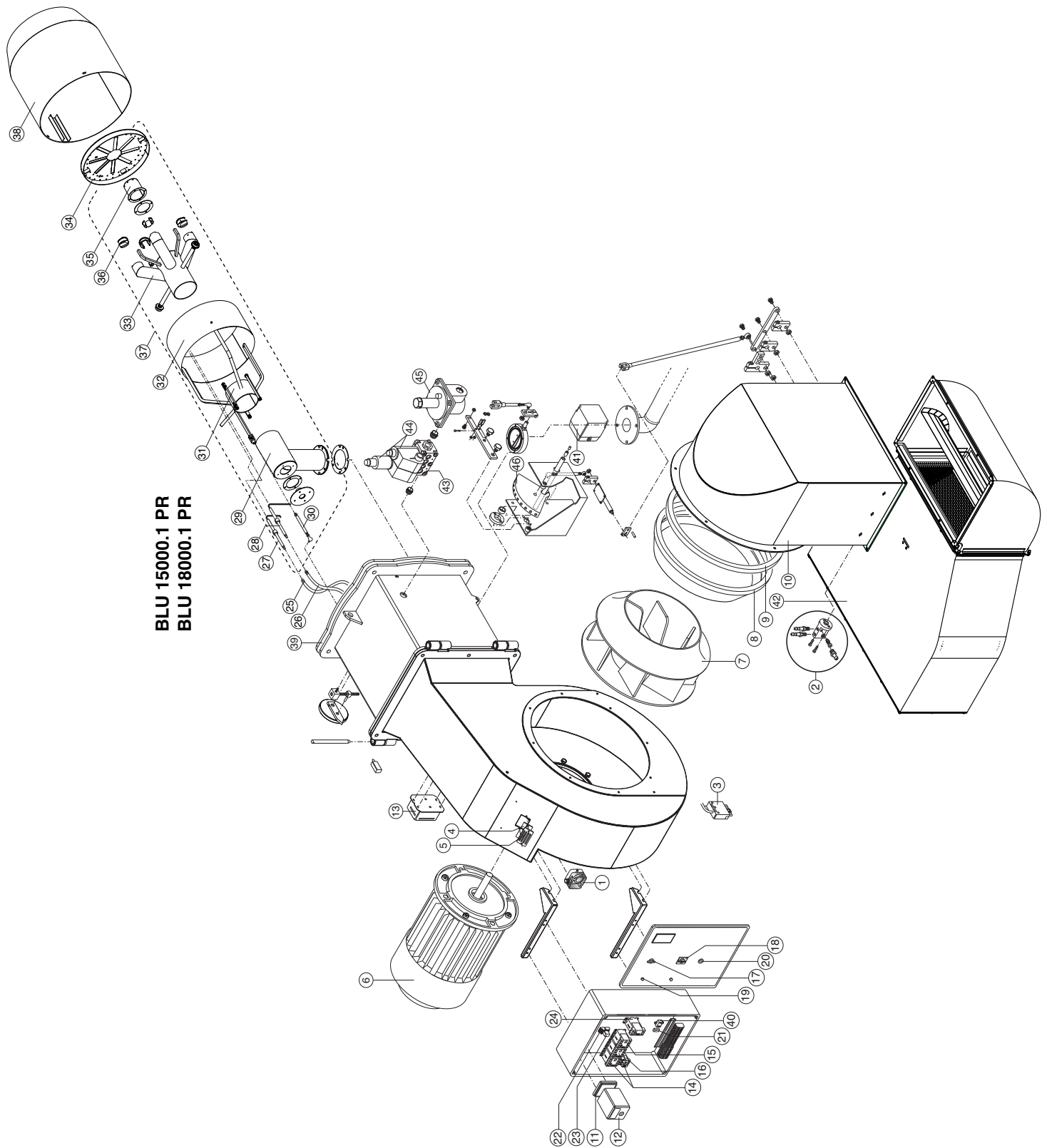

APPENDIX

Spare parts list

N°	DESCRIPTION		BLU 15000.1 PR	BLU 18000.1 PR
			code	code
1	AIR PRESSURE SWITCH	LGW 10 A4	65323033	65323033
2	AIR INTAKE SET		65324294	65324294
3	WIELAND PLUG	6 pin	65322072	65322072
4	GLASS		65320487	65320487
5	PEED WINDOM FRAME		65320488	65320488
6	MOTOR	45 kW	65325420	-
		55 kW	-	65324463
7	FAN	GR-710/2 M.d.55	65324934	-
		GR-710/2 M.d.60	-	65324464
8	AIR CONVEYOR		65324465	65324465
9	RING		65324466	65324466
10	AIR INTAKE		65325419	65325419
11	CONTROL BOX BASE	Landis	65320091	65320091
12	CONTROL BOX	Landis LFL1.333	65320031	65320031
13	IGNITION TRANSFORMER	COFI 820 PM	65323227	65323227
14	REMOTE CONTROL SWITCH	AEG LS22K.00	65323134	-
		11BF6500230	-	65324935
15	REMOTE CONTROL SWITCH	AEG LS15K.00	65323136	-
		BF3800A230	-	65323127
16	MOTOR THERMAL RELAY	AEG 42-55A	65324067	-
		11BF95382 60-82A	-	65324936
17	MAIN SWITCH	COMEPI ART.ECX1252	65324098	65324098
18	SELECTOR	Giovenzana a.C01600029	65323063	65323063
19	LAMP	BA9S 240V-3W	65324421	65324421
20	RESET BUTTON	COMEPI art.ECX1201	65324101	65324101
21	FUSE SUPPORT	HK 520 04/1 10A	65324279	65324279
22	RELAY BASE	Finder 5532	65323149	65323149
23	RELAY	Finder 5532	65323139	65323139
24	TIMER	AEG GMETV	65324073	-
		TMST	-	65325035
25	IGNITION CABLE	TC	65322004	65322004
26	IONIZATION CABLE	TC	65322004	65322004
27	IGNITION ELECTRODE		65324528	65324528
28	IONIZATION PROBE		65324529	65324529
29	PIPE	TC	65324532	65324532
30	ROD	TC	OFS03265-001	OFS03265-001
31	TRUCK		65324908	65324908
32	WAISTBAND		65324470	65324470
33	FIRING HEAD		65324534	65324534
34	DISC		65324141	65324141
35	FRONT PIPE		65321611	65321611
36	DIFFUSER		65324535	65324535
37	INNER ASSEMBLY	TC	65325365	65325365
38	BLAST TUBE	TC	65324477	65324477
39	GASKET		65324478	65324478
40	ANTIJAMMING FILTER		65323170	65323170
41	AIR DAMPER MOTOR	SQM50.481A2	65322902	65322902
42	SILENCER		65324537	65324537
43	GAS VALVE	KROMSCH.VCS 125R-LW	65324722	65324722
44	COIL	KROMSCH.VCS 125R-LW	65324623	65324623
45	GAS GOVERNOR/FILTER	1/2 FG1B 25	65325214	65325214
46	GAS CAM GROUP		65322355	65322355

TC = SHORT HEAD TL = LONG HEAD

Ecoflam

Ecoflam Bruciatori S.p.A.

Via Roma, 64 - 31023 Resana (TV) - Italy

Tel. +39 0423 719500

Fax +39 0423 719580

<http://www.ecoflam-burners.com>

e-mail: export@ecoflam-burners.com

Società soggetta alla direzione e al coordinamento di Ariston Thermo S.p.A.

Via A. Merloni, 45 - 60044 Fabriano (AN) - CF 01026940427

Ecoflam Bruciatori S.p.A. reserves the right to make any adjustments, without prior notice, which is considered necessary or useful to its products, without affecting their main features

Ecoflam Bruciatori S.p.A. si riserva il diritto di apportare ai prodotti le modifiche che riterrà necessarie o utili, senza pregiudicarne le caratteristiche principali.

La maison Ecoflam Bruciatori S.p.A. se réserve le droit d'apporter les modifications qu'elle jugera nécessaires ou utiles à ses produits sans pour autant nuire à leurs caractéristiques principales

Ecoflam Bruciatori S.p.A. se reserva el derecho a introducir en sus productos todas las modificaciones que considere necesarias o utiles, sin perjudicar sus características

"Ecoflam Bruciatori S.p.A." оставляет за собой право вносить в конструкцию оборудования любые необходимые изменения без особого предупреждения